

Refer to pg. 32-33 of the Commercial Section in the Gibraltar Fabrication Manual for cutout procedures

Copyright © 2003, All Rights Reserved

 **Wilsonart® Solid Surface**

Wilsonart International Inc.  
2400 Wilson Place  
P. O. Box 6110  
Temple, TX 76503-6110

ACAD FILE: Food Service Bar.dwg

DEPT: Solid Surface

DR: RWM

CKD:

APPR:

SHEET TITLE:

FOOD SERVICE BAR

CUTOUT SUPPORT

WOOD FRAMING

SCALE:

NTS

DATE:

05/01/03

DRAWING NO:

FSB-001

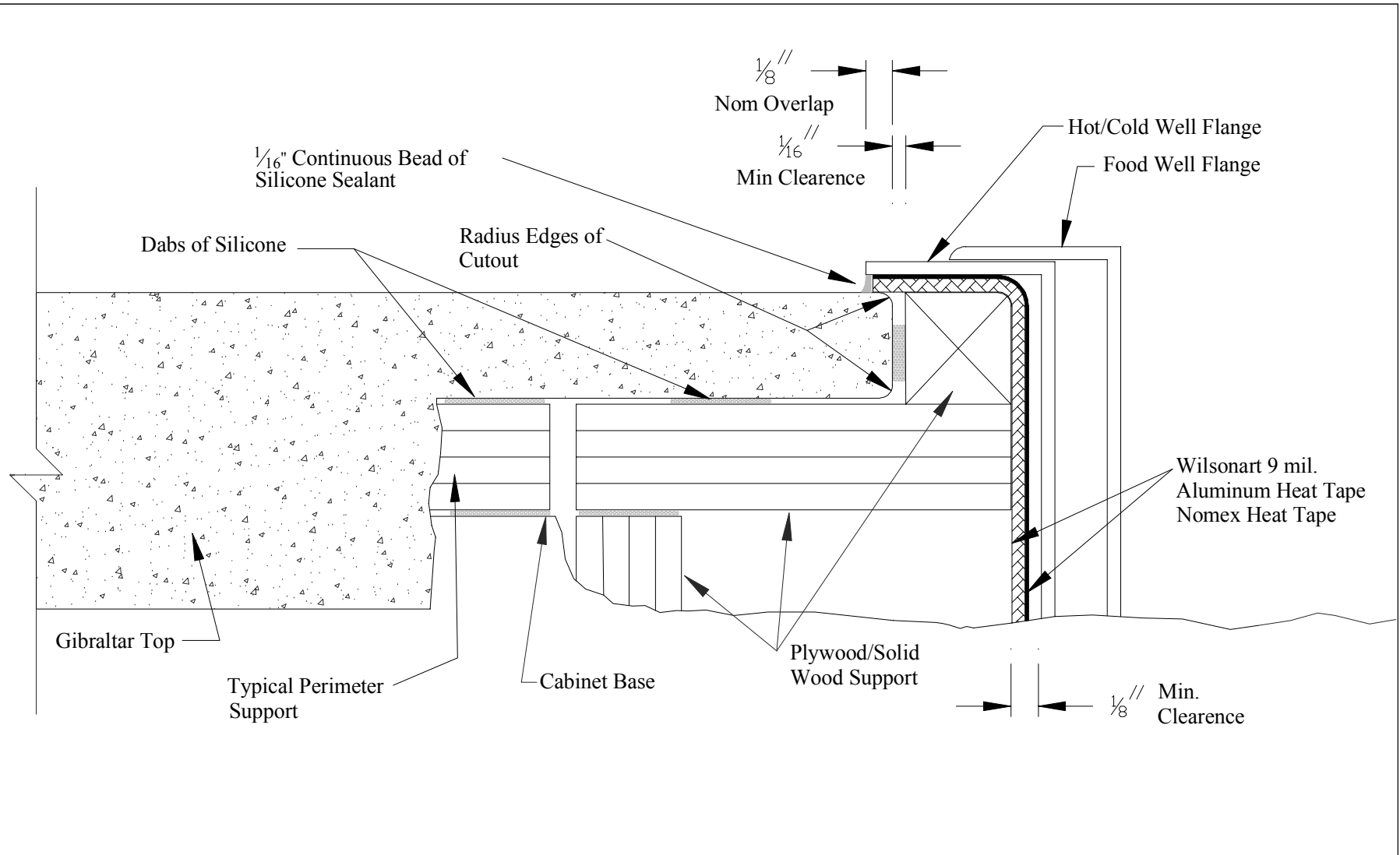

Refer to pg. 32-33 of the Commercial Section in the Gibraltar Fabrication Manual for cutout requirements

Copyright © 2003, All Rights Reserved

**Wilsonart® Solid Surface**

Wilsonart International Inc.  
 2400 Wilson Place  
 P. O. Box 6110  
 Temple, TX 76503-6110

ACAD FILE: Food Service Bar.dwg
DEPT: SOLID SURFACE
DR: RWM
CKD:
APPR:

SHEET TITLE:
FOOD SERVICE BAR CUTOUT
WOOD FRAMING SUPPORT
SECTION A-A

SCALE:
NTS
DATE:
06/01/03
DRAWING NO:
FSB-002

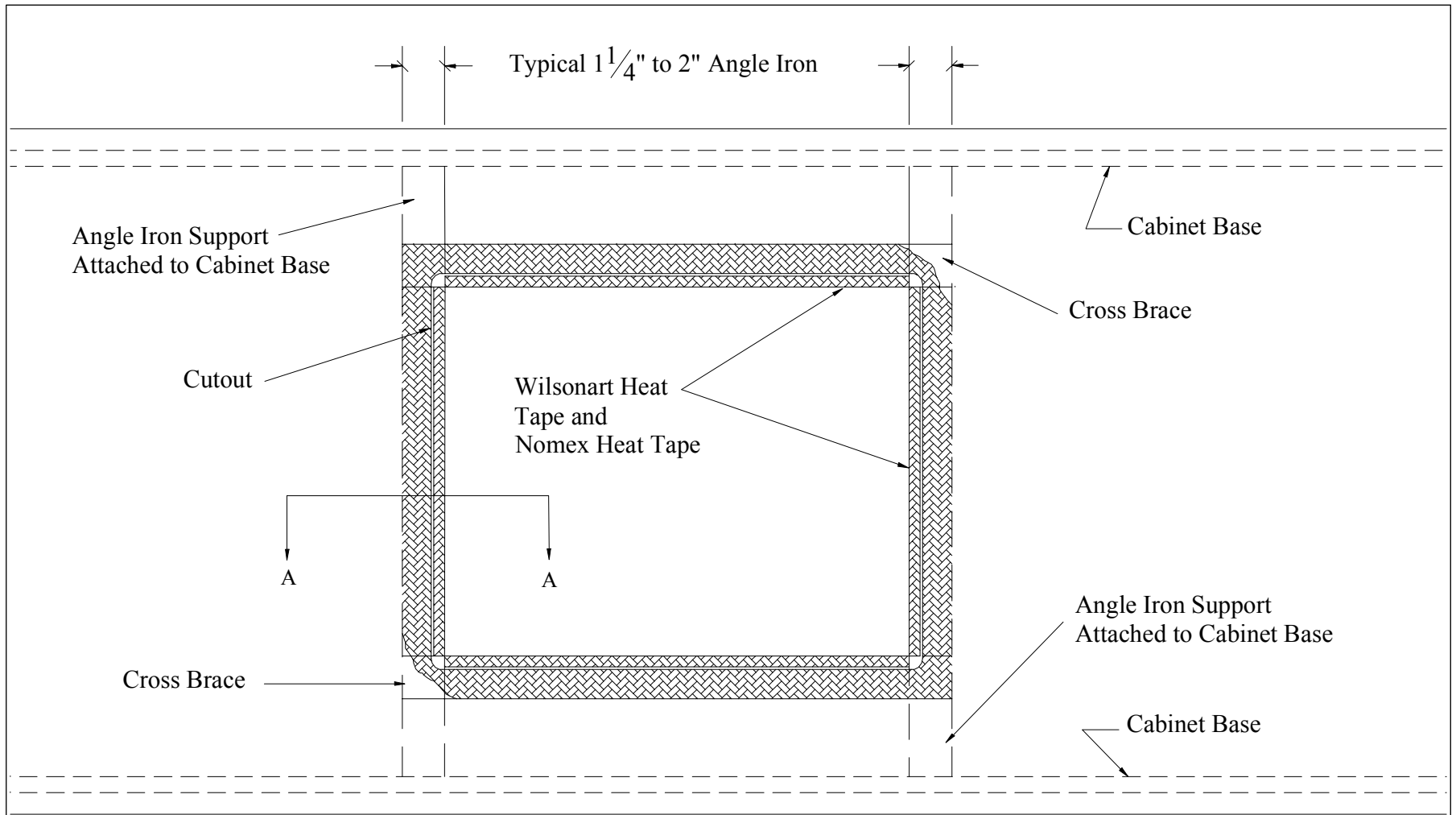

Refer to pg. 32-33 of the Commercial Section in the Gibraltar Fabrication Manual for cutout requirements

Copyright © 2003, All Rights Reserved



**Wilsonart® Solid Surface**

Wilsonart International Inc.  
 2400 Wilson Place  
 P. O. Box 6110  
 Temple, TX 76503-6110

ACAD FILE: Food Service Bar
DEPT: SOLID SURFACE
DR: RWM
CKD:
APPR:

SHEET TITLE:
FOOD SERVICE BAR
CUTOUT SUPPORT
ANGLE IRON

SCALE:
NTS
DATE:
06/01/03
DRAWING NO:
FSB-003

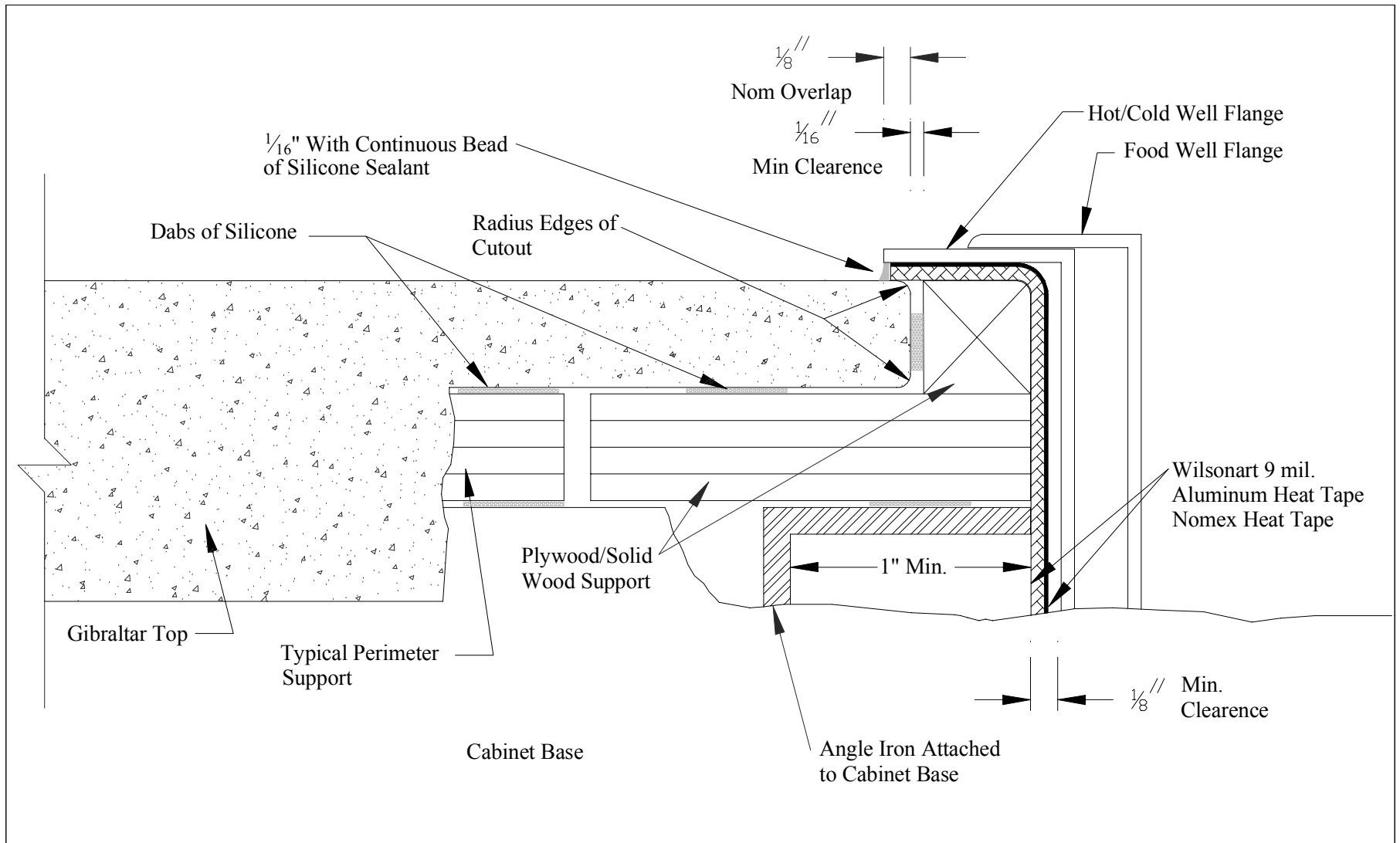

Refer to pg. 32-33 of the Commercial Section in the Gibraltar Fabrication Manual for cutout requirements

Copyright © 2003, All Rights Reserved

**Wilsonart® Solid Surface**

Wilsonart International Inc.  
 2400 Wilson Place  
 P. O. Box 6110  
 Temple, TX 76503-6110

ACAD FILE: Food Service Bar
DEPT: SOLID SURFACE
DR: RWM
CKD:
APPR:

SHEET TITLE:
FOOD SERVICE BAR CUTOUT
METAL SUPPORT OPTION
SECTION A-A

SCALE:
NTS
DATE:
06/01/03
DRAWING NO:
FSB-004

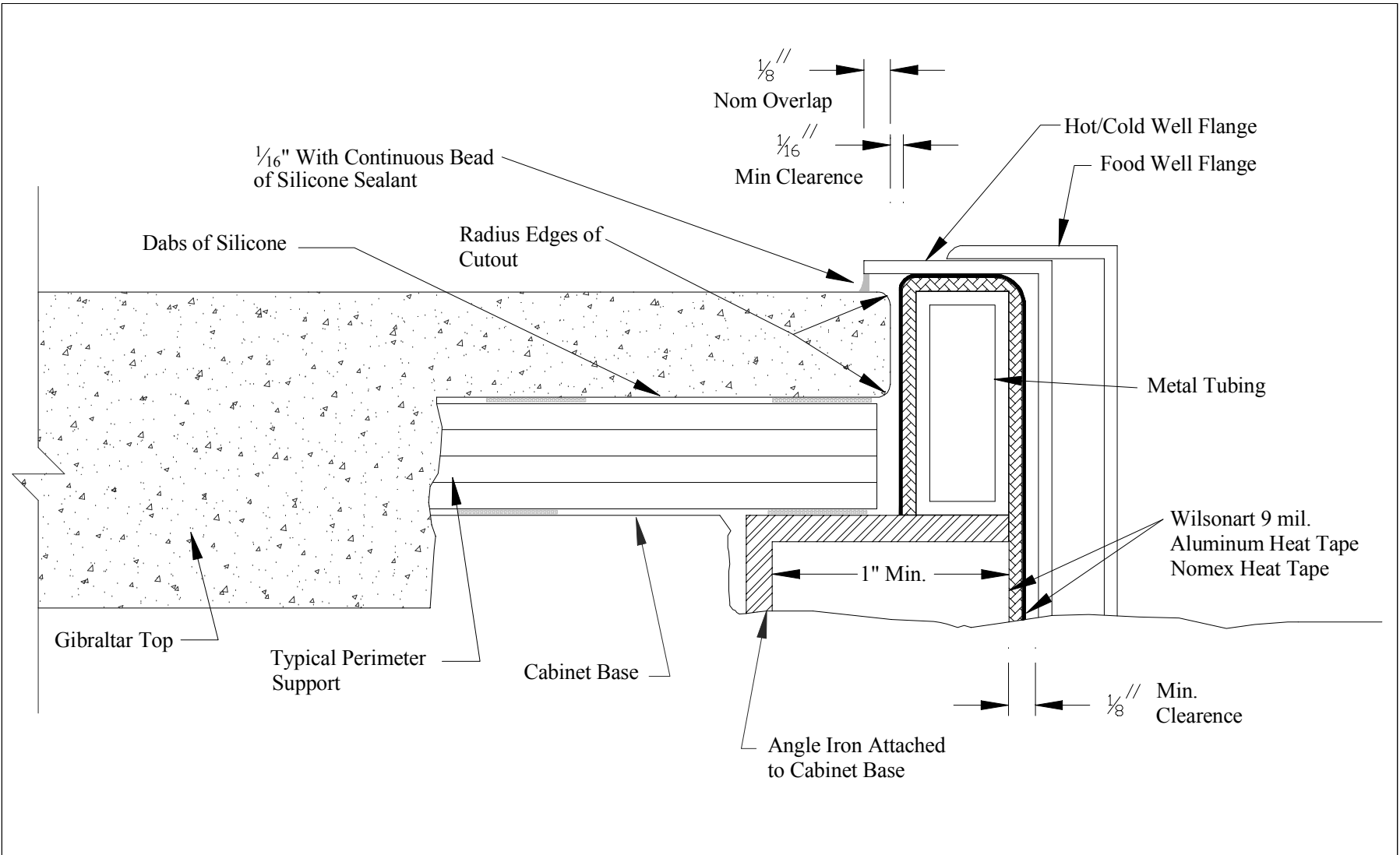

Refer to pg. 32-33 of the Commercial Section in the Gibraltar Fabrication Manual for cutout requirements

Copyright © 2003, All Rights Reserved

# Wilsonart® Solid Surface

Wilsonart International Inc.  
 2400 Wilson Place  
 P. O. Box 6110  
 Temple, TX 76503-6110

ACAD FILE: Food Service Bar
DEPT: SOLID SURFACE
DR: RWM
CKD:
APPR:

SHEET TITLE:
FOOD SERVICE BAR CUTOUT
METAL SUPPORT OPTION
SECTION A-A

SCALE:
NTS
DATE:
06/01/03
DRAWING NO:
FSB-005

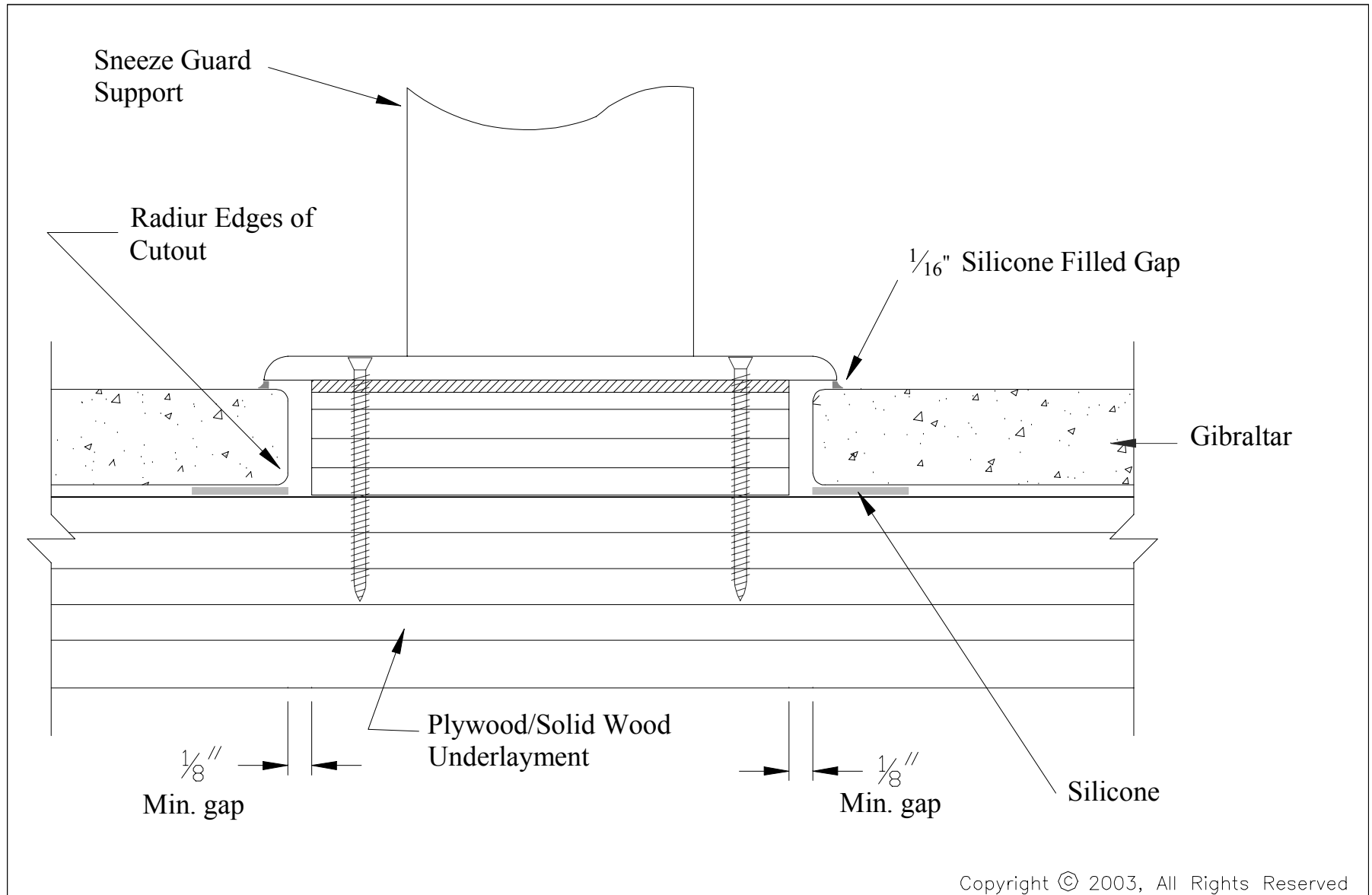

**Wilsonart® Solid Surface**

Wilsonart International Inc.  
 2400 Wilson Place  
 P. O. Box 6110  
 Temple, TX 76503-6110

ACAD FILE: Food Service Bar
DEPT: SOLID SURFACE
DR: RWM
CKD:
APPR:

SHEET TITLE:
FOOD SERVICE BAR
SNEEZE GUARD
SECTION VIEW

SCALE:
NTS
DATE:
06/01/03
DRAWING NO:
FSB-006

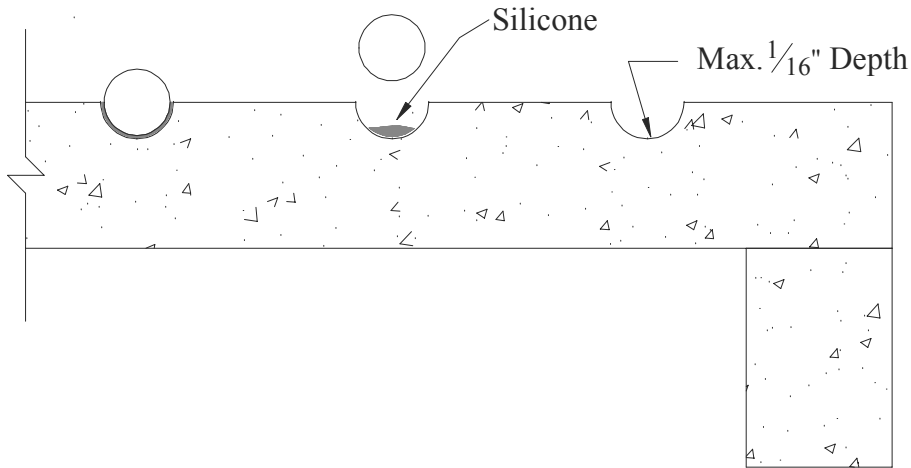
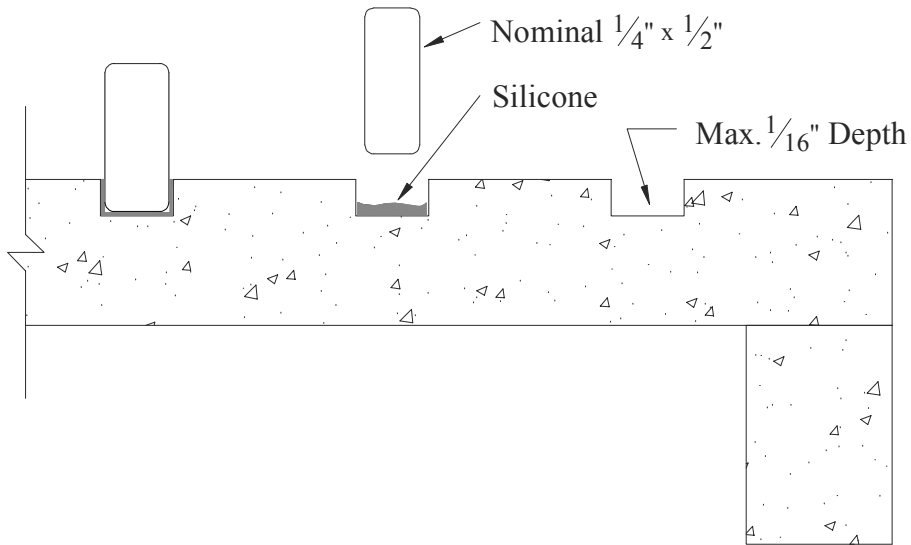

Notes:

1. Tray Slide Inserts Shape & Size as Desired
2. Inserts can be Gibraltar, Metal, Plastic, etc.
3. Maximum Insert Depth  $\frac{1}{16}$ "
4. Ease All Edges
5. Drop Edge Thickness and Profile as Desired  
(see Popular Profile Options for Details)
6. See Gibraltar Fabrication Manual for Tray Slide Support Requirements.

Copyright © 2003, All Rights Reserved

 **Wilsonart® Solid Surface**

Wilsonart International Inc.  
2400 Wilson Place  
P. O. Box 6110  
Temple, TX 76503-6110

ACAD FILE: Food Service Bar
DEPT: SOLID SURFACE
DR: RWM
CKD:
APPR:

SHEET TITLE:
FOOD SERVICE BAR
TRAY SLIDE OPTIONS
SECTION VIEW

SCALE: NTS
DATE: 06/01/03
DRAWING NO: FSB-007